



# Spherolinder® Ruggedized Kinematic Mount Datasheet (PRELIMINARY)

A Spherolinder mount maintains a kinematic coupling between two rigid components. The mount is comprised of three “stacks”, each forming a two-degrees-of-freedom connection between the two components, essentially acting like a “sphere-in-groove” mate, but with much higher (~100x) load capacity and rigidity.



-BTM Groove (V) side -TOP Cone (C) side

To form a mount, the three BTM assemblies are attached to the “baseplate”, with their V axes pointing roughly towards their centroid (other configurations are possible too). The TOP assemblies are attached to the “load plate”, co-centric to their respective BTM assemblies.

During assembly, and in response to post-assembly deformations of the two components due to load or temperature, the Spherolinders slide in their V blocks in the same way that the spheres move in a traditional three-groove mount, but due to the line contacts between them, the movement is smoother and has less friction, wear, or galling. The C blocks slide over the Spherolinder to compensate for tip/tilt.

For applications that require retention, (e.g. dynamic loads or gimbaling), a “Through” retainer extends from the baseplate (V side), through the Spherolinder and C block, and captures the load plate using a locknut and Belleville washers, so that the retention is compliant and does not over-constrain the mount. For static horizontal assemblies a shorter “Blind” retainer is used, which does not extend past the C block.



Blind (-B) and Through (-T) retainers

The Spherolinder and mounting (V and C) blocks are made of Stainless Steel 440c. The retainers, clamp plates, and transport jacks are made of Stainless Steel 17-4Ph. Standard fasteners are made of Stainless Steel 18-8.

Spherolinders are available in three standard sizes.

The load limit is derived from the minimum of:

- 50% of the calculated Hertzian yield point.
- 50% of the calculated tensile load of the retainer.

Size	Mating Stack Load Limit*
(M05)	75 kg [170 lb]
M10	300 kg [670 lb]
M15	750 kg [1600 lb]
M25	1900 kg [4200 lb]
M50	7600 kg [17,000 lb]

\*Per each mount point

The stated load limit is per mating stack, so if distributed equally, the mount can carry 3x that load.

The stated load includes any preload that is applied through the retainer, which depends on the amount of retention required by the application. For example, for a nominal upside-down-capable mount, the preload equals to the load, and so the effective load is doubled (and therefore the mount should be de-rated by a factor of 2). If the mount will be exposed to a transient 4g acceleration in random directions, the preload must equal three times the weight of the load, and the effective load can be Septupled, so the mount should be de-rated by a factor of 7.

	M10	M15	M25	M50
Stack height h (mm)	15.2	22.8	38.0	72.0
Mount block diameter OD (mm)	15.0	22.5	37.5	74.0
Spherolinder travel range x (mm)	±0.4	±0.8	±1.0	±2.0
Retainer thread	M5	M6/8	M12	M20
-FR retainer overheight rh (mm)	12	18	30	40
-TR retainer overheight rh (mm)	18	27	45	--

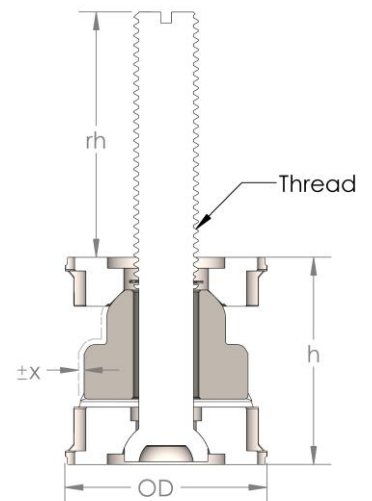



# Spherolinder® Ruggedized Kinematic Mount Datasheet (PRELIMINARY)

ENGINEERING

The Spherolinder assembly is offered in two main flavors.

In the “Fixed Retainer” system the retainer bolts directly to the baseplate and remains perpendicular to it. When the C Block (and Spherolinder) move along the axis of the V Groove (Due to thermal expansion, for example), the top-side Belleville and nut slide on the back of the load plate. This motion has some small amount of stiction.

In the “Tilting Retainer” system, the Retainer tilts to follow the motion of the Spherolinder by tilting. To achieve this motion, the retainer is no longer bolted directly to the baseplate but is instead captured in a ball socket within the V-Block, which is in turn clamped to the baseplate to support tensile loads. This reduces stiction but increases the footprint and complexity of the assembly.

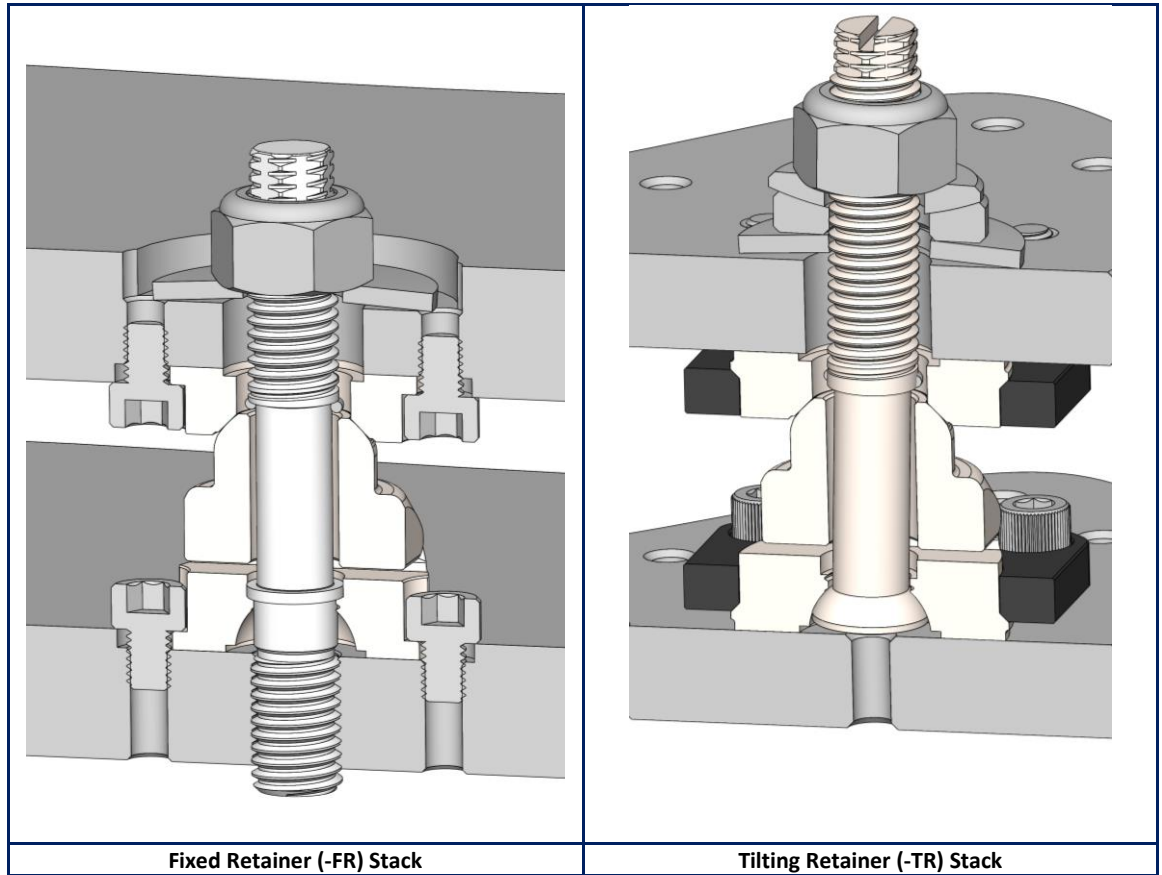

The Fixed Retainer assembly is almost identical to our legacy configuration, with the exception that the retainer thread size is now upgraded: M4 → M5 for the M10 Spherolinder, and M10 → M12 for the M25 Spherolinders.

The tilting retainer has a similar top thread, but is free to swivel. Because of this, it does not need to be torqued into place, but installation of the lock-nut is done using a hollow-shaft ratchet tool in conjunction with a screwdriver.



# Spherolinder® Ruggedized Kinematic Mount

## Datasheet (PRELIMINARY)

### Mounting and Shear

In the fixed retainer (-FR) system, the V block is always loaded in compression, and tensile load transfers from the retainer directly to the baseplate. In the tilting retainer (-TR), the tensile load path passes from the retainer to the V block and a clamp plate to the baseplate. We offer a standard 4-bolt square plate that works with optical grids (-OTx) but can also customize the bolt pattern of the clamp for any setup.

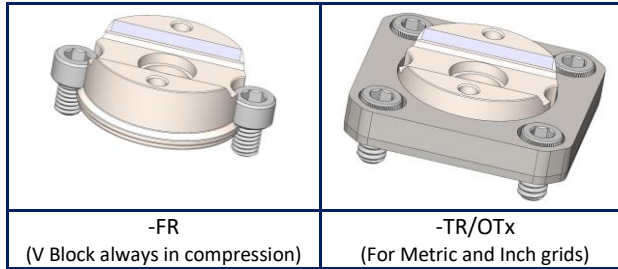

In either system (-FR or -TR) the C block is always loaded in compression, but can still use the OTx clamp plate for mounting on an optical table grid.

	M10	M15	M25	M50
-FR Bolt	M3/#5		M6/.25"	M12/.5"
-FR Bolt Separation (mm)	16.0		40.0	78.0
-OTx Plate Width (mm)	38	50	50	
-OTx Grid Pattern Size	4-hole	5-hole	5-hole	
-OTx Bolt	M6/.25"	M6/.25"	M6/.25"	
-OTx Bolt spacing	1 grid	1.41 grid	1.41 grid	

Shear load is transferred through pins inserted at the base of the mounting block. The M10 and M25 blocks use a pair of C-pins pressed into matching holes, and the M50 blocks use solid dowel pins and require a pin-and-slot interface in the plate they are mount to.

Alternatively, the blocks can be placed inside a machined pocket and potted in place or even pressed into the pocket.

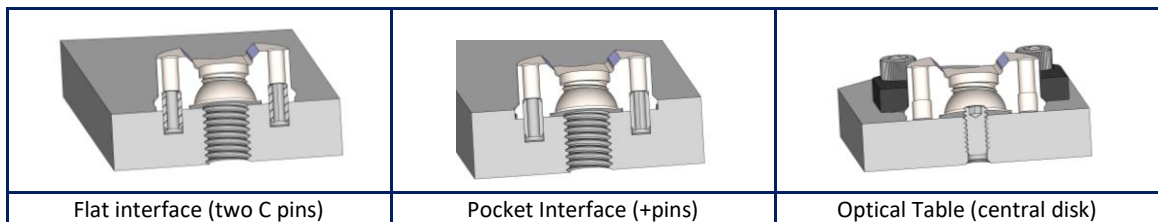

The pin holes are threaded at their upper portion, to be used to extract the block using set screws.

	M10	M15	M25	M50
-PIN Hole diameter (mm)	2.0	3.0	5.0	--
-PIN Hole separation (mm)	11.00 ±0.01	17.00 ±0.01	28.00 ±0.01	--
-OTx center thread	--	M6/.25"	M6/.25"	--



# Spherolinder® Ruggedized Kinematic Mount Datasheet (PRELIMINARY)

ENGINEERING

The Transport/Assembly Jack is intended to provide a parallel and more rigid load path around the Spherolinder to prevent damage due to high unexpected loads during transport. The jack can also be used during assembly to protect the Spherolinder from impact load.

**For use as a transport jack:**

The jack offloads the kinematic components of the mount, but should not lift the payload a meaningful amount and disengage the kinematic mount. If the kinematic components are separated, they might then shift sideways during transport which is not desirable.

The jack should supply an upwards force equal to about half of the static load on the Spherolinder. Once installed, and being much more rigid than the Spherolinder, the Jack can withstand bump loads up to the Max value in the table below.

Since the mount is already stacked, disassemble the two halves of each jack and re-assemble them around the Spherolinder. Lightly tighten both screws until both wedges engage. (Avoid tightening one screw before the other engages). The engagement should occur about 1-2 mm before the jack’s end-of-travel, but the exact point depends on manufacturing tolerances.

**For use as an assembly jack:**

Since the mount is not yet stacked, tighten the bolts until the jack is 0.1 mm taller than the nominal height (NH), then place it on top of the V block and around the Spherolinder before stacking the C blocks and payload. This will protect the kinematic components from any drop load. Again, ensure that both sides are equally engaged. Since no vibration is anticipated, regular nuts will suffice. Finally, disengage the screws to settle the mount, disassemble the jack, and remove the two halves.

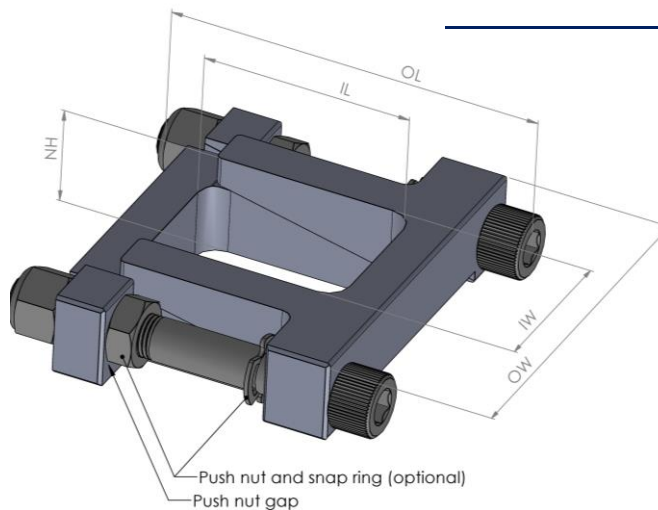

(mm)	OL	OW	NH	IL	IW
M10	—	—	—	—	—
M25	57.2	56.6	15	32	24
M50	114.5	113.1	30	64	48

	Max kN	Max lb
M10	—	—
M25	57	12600
M50	230	51000

**Wedge Material:** SS 17-4 PH Cond A  
**Bolts:** Stainless Steel UNF Class 50

Lubrication of the sliding surfaces is encouraged. At a 12° wedge angle, we don’t expect seizing of the wedges, but if a concern exists, we are providing a push nut and snap ring that can be used to push the two wedges apart. The nut needs to be installed during jack assembly, leaving about 1 mm of gap where indicated.



ENGINEERING

# Spherolinder® Ruggedized Kinematic Mount Datasheet (PRELIMINARY)

## Ordering

The basic part number scheme is (Assemblies -or- Components):

$$\begin{array}{ccccccc}
 & 10 & \text{STK} & & & & 10 \\
 & 15 & \text{BTM} & \text{FR} & \text{T} & & 15 \\
 \text{SPH} & 25 & \text{TOP} & \text{TR} & \text{B} & \text{-or-} & \text{SPH} & 25 & \text{[CMP]} & \text{B} & \text{[MTL]} \\
 & 50 & \text{JCK} & & \text{H} & & & 50 & & & \text{H}
 \end{array}$$

-SPHxx	Sphere size: M10, M25 or M50. (M15 coming soon, other sizes are possible)
-STK	One vertical mounting point assembly, comprised of a -BTM and -TOP subassemblies
-BTM	Subassembly: V Block, Spherolinder, Retainer, clamp plate (-TR)
-TOP	Subassembly: C Block and pins, clamp plate (-TR)
-JCK	Jack assembly, comprised of two wedge subassemblies, preassembled)
-FR / -TR	Retention System: Fixed or Tilting (Tilting implies clamp plates)
-T/-B/-H	Retention type: Through / Blind / Hat
-[CMP]	Component, one of: SP / BV / BC / RF / RT / PCV / PCC
-[MTL]	SS1: SS440C / SS2: SS 17-4PH / SS3: Nitronic 60

-TOP and -JCK assemblies do not require retention specifiers

Unless requested otherwise:

- Subassemblies include mounting hardware
- Pins are pre-installed in the V and C blocks
- When possible, components are pre-assembled even if ordered separately

Examples:

- SPH50-STK-FR-T      A single mount point for an M50 fixed-retainer through mount
- SPH10-BTM-FR-T-SET      Three bottom subassemblies for an M10 fixed-retainer through mount
- SPH25-BTM-TR-T      A single bottom subassembly for an M25 tilting-retainer through mount
- SPH50-JCK-SET      Three jack assemblies for M50 Spherolinder
- SPH25-SP-SS1      A single M25 Spherolinder



# Spherolinder® Ruggedized Kinematic Mount Datasheet (PRELIMINARY)

ENGINEERING

### Fixed Retention System:

In the FR system, the BTM subassembly consists of a V Block, and a soft-captive subassembly consisting of a retainer and a Spherolinder, which bolts directly into the baseplate. The V Block C-pins pre-installed.

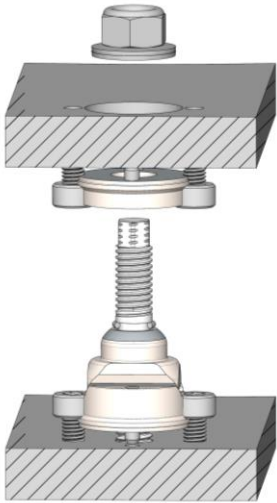

1. If you're not intending to use the C-pins, pull them out of the V Block and discard them.
2. Ensure the retainer is fully seated in the V Block, with the Spherolinder located in the groove.
3. Engage the retainer bottom thread into the central threaded hole of the baseplate mount.
4. Turn the retainer until the C-pins make initial contact with their holes in the baseplate.
5. Install the two side bolts and screw them in until their heads contact the V Block.
6. Using the retainer and the two side bolts, fully seat the V Block to the baseplate.
7. Torque the retainer up to a max value comparable to a class 5 stainless bolt.

The TOP subassembly consists of only a C Block and installs onto the load plate in a similar manner to the BTM subassembly, but without the retainer thread.

Repeat for all three mount points, and then mate the baseplate and load plate. For Through and Hat retainers, assemble the Belleville washers and lock/hat nuts to secure the mount. Turn the nuts until finger-tight and then further in accordance of thread pitch and Belleville parameters to achieve the desired preload.

### Tilting Retention System:

In the TR system, the BTM subassembly additionally includes a clamp plate, replacing the side bolts. The retainer and Spherolinder are fully captive, and the retainer does not thread into the baseplate.

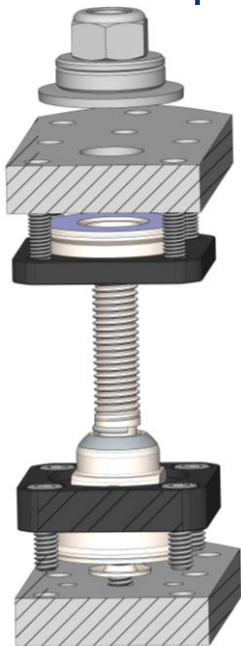

1. If you're not intending to use the C-pins, pull them out of the V Block and discard them.
2. If you're using a centration disc, install it in the center thread of the baseplate
3. Place the BTM clamp plate (thicker) around the V Block.
4. Place the BTM assembly on the baseplate so that the C-pins align with their holes.
5. Install the four corner bolts and screw them in until their heads contact the V Block,
6. Using the corner bolts, push the V Block down until fully seated.
7. The C-pins should conform and slide into their holes.

The TOP subassembly additionally includes a clamp plate (thinner) and installs onto the load plate in a similar manner to the BTM subassembly.

Once the baseplate and load plate are mated, for Through and Hat retainers, assemble the Spherical and Belleville washers and lock/hat nuts to secure the mount. To install the nut, use a hollow-shaft ratchet tool, keeping the retainer from rotating using a flat-end screwdriver. Turn the nuts until finger-tight and then further in accordance of thread pitch and Belleville parameters to achieve the desired preload.